

PART NO. FT-C015-U113229
 CUST NO.

CUSTOMER DRAWING

REVISIONS			
LTR	DESCRIPTION	DATE	APPROVED
Ⓑ	CHANGE WIRING DIAGRAM.	2024.03.06	Bryan Ho
Ⓒ	CHANGE P2 BODY AS RED COLOR.	2024.03.25	Bryan Ho

RoHS

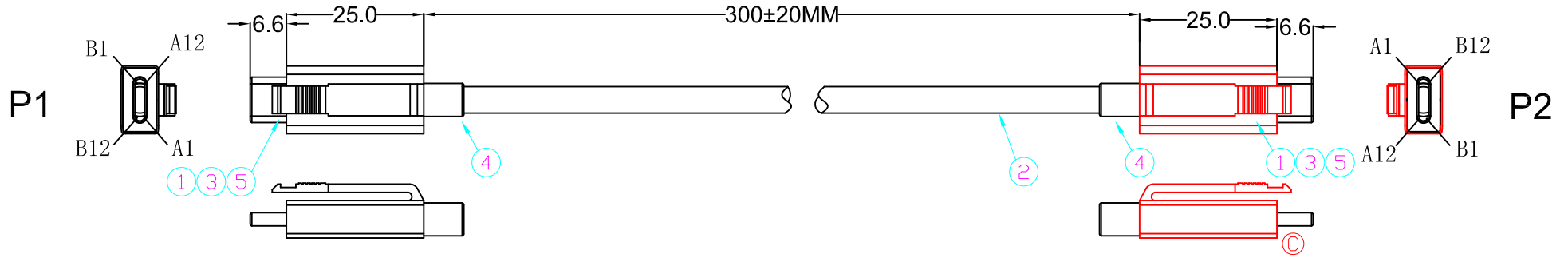

CABLE:
 CONDUCTOR:(32AWG*1PAIR+D+AL/MY)*4C+(32AWG*1P+AL)*1C +32AWG*4C+22AWG*1C
 + F+AL+DRAIN WIRE(24AWG)+BRAID

OD:□4.8±0.15mm
 COLOR: BLACK

Ⓑ WIRING DIAGRAM

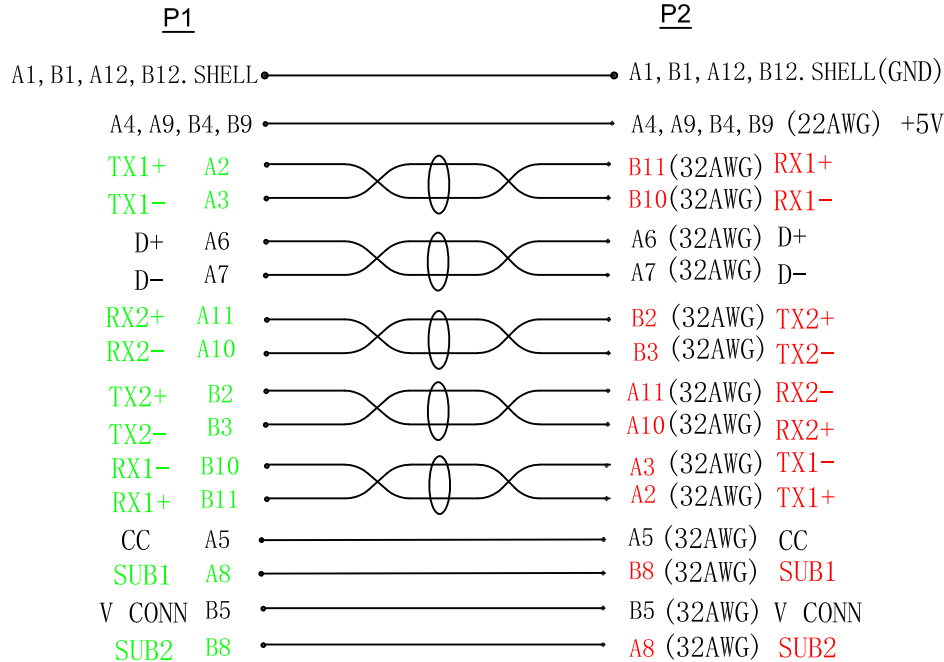

ELECTRICAL PROPERTIES:

- 100% OPEN SHORT MIS-WIRE TEST.
- Contact Resistance: 3 ohm.
- Insulation Resistance:5 Mega ohm.
- Hi-pot test:DC 300V/10ms.
- SOLDERING COPPER FOIL ONTO THE INNER MOLDING.

NOTE	DESCRIPTION
1	USB 3.1 TYPE-C (MALE) CONNECTOR *2PCS NICKEL PLATED
2	USB 3.1 TYPE-C CABLE
3 Ⓒ	ASSEMBLY PLASTIC SHELL BODY, BLACK/RED.
4	TPE MOLDING SR
5	LD-PE INTERNAL MOLDING

UNLESS OTHERWISE SPECIFIED DIMENSIONS ARE IN MILLIMETERS ANGULAR TOLERANCE: XXXXX		APPROVALS DRAWN PETER. YEH	DATE 2024.03.25	
		CHECKED SANDY.CHEN	2024.03.25	
		APPROVAL BRYAN.HO	2024.03.25	USB 3.1 TYPE-C TO USB TYPE - C UL20276 CABLE L=300MM,Latches.
DIMENSIONS	TOLERANCE	SIZE	SCALE : XX : XX	
.X	±0.5	C	DRAWING NO. FT-C292-839	
.X.	±1			
XX.	±10	REV. C		
XXX.	±50	SHEET 1 OF 1		