

PART NO. FT-C015-U113964
 CUST NO.

CUSTOMER DRAWING

REVISIONS			
LTR	DESCRIPTION	DATE	APPROVED

RoHS

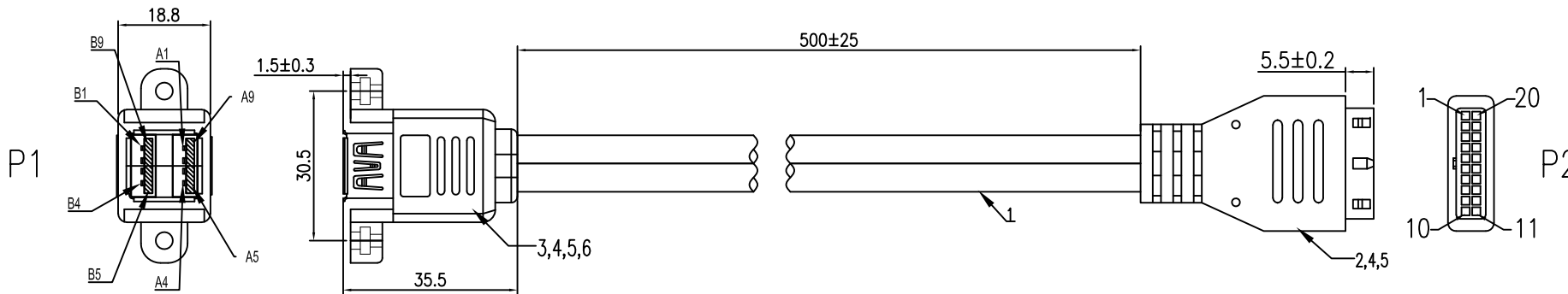

USB A,B

PIN ASSIGNMENT:

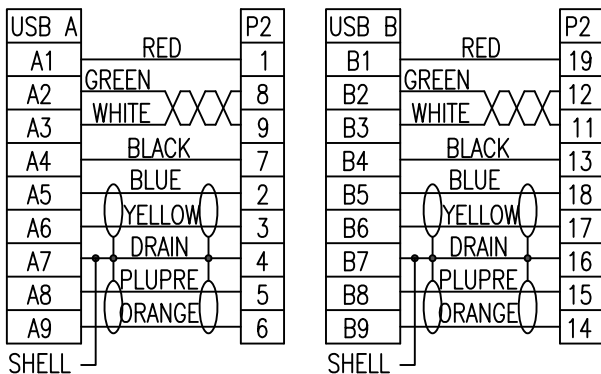

ITEM	DESCRIPTION	QTY
6	M3 SCREW NUT *2	
5	OVER-MOLDING: PVC 45P, BLACK, ROHS	
4	INNER MOLDING: LD-PE	
3	USB3.0 A-TYPE FEMALE *2 CONNECTOR, PLATING:G/F ,BODY: BLUE COLOR, NICKEL SHELL, ROHS	1
2	IDC USB3.0 2X10P (20P PLUG) CONNECTOR, SOLDERING TYPE,BODY: BLUE COLOR, ROHS	2
1	UL20276(30#x1P+DAM)x2+30#x1P+26#x2C+F+AEB(16*6/0.12AM) OD5.5mm BLACK, IBC-003 USB3.0 HALF-MATT ROHS	2

NOTE:

- 100% TEST OPEN SHORT & MIS-WIRE
- CONDUCTION RESISTANCE: 2 Ohm (MAX)
- INSULATION RESISTANCE: 5M Ohm (MIN)
- HIPOT TEST:DC 300V, 0.01/S.

UNLESS OTHERWISE SPECIFIDE DIMENSIONS ARE IN MILLIMETERS ANGULAR TOLERANCE: XXXXX		APPROVALS	DATE	FutronicTechnology		
DRAWN		PETER.YEH	2024.10.15	USB3.0 A/Fx2 TO USB3.0 IDC 2X10P CABLE L=0.5M, PANEL MOUNTED TYPE.		
CHECKED		SANDY.CHEN	2024.10.15			
APPROVAL		BRYAN.HO	2024.10.15	SIZE	SCALE :	DRAWING NO.
DIMENSIONS		TOLERANCE		C	xx : xx	KY-I024-1006
.X	±0.5			REV.	A	
X.	±1			SHEET 1 OF 1		
XX.	±10					
XXX.	±50					