

PART NO. FT-C015-P113969  
 CUST NO.

# CUSTOMER DRAWING

REVISIONS			
LTR	DESCRIPTION	DATE	APPROVED

**RoHS**

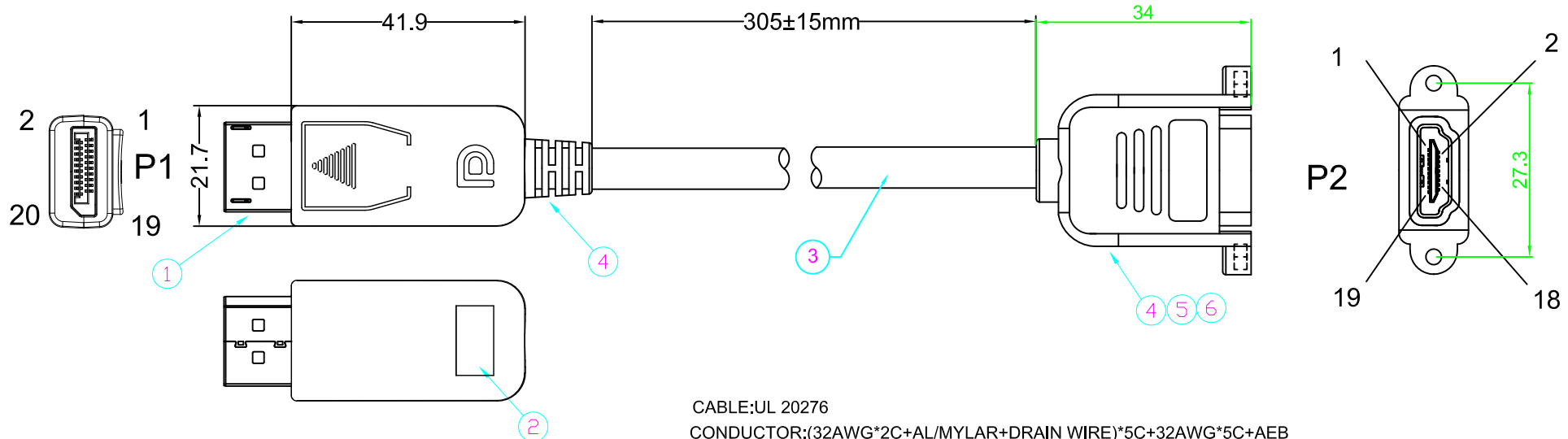

CABLE:UL 20276  
 CONDUCTOR:(32AWG\*2C+AL/MYLAR+DRAIN WIRE)\*5C+32AWG\*5C+AEB  
 JACKET:PVC , OD:□5.0±0.15mm  
 COLOR:BLACK

## PIN ASSIGNMENT

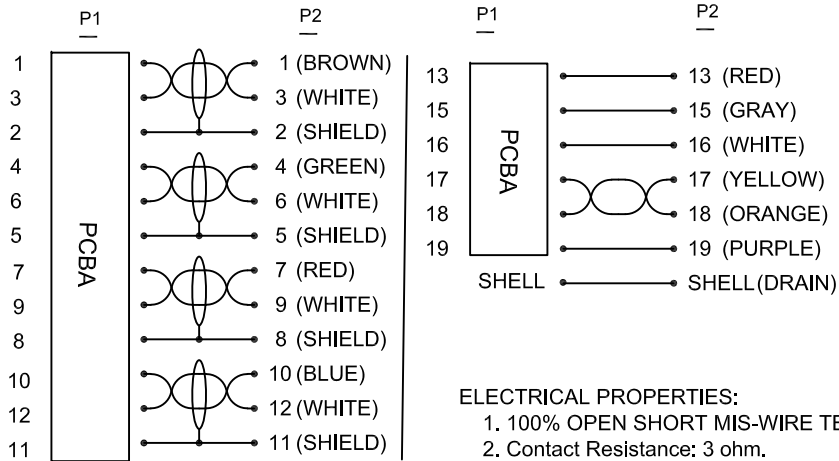

- ELECTRICAL PROPERTIES:**
- 100% OPEN SHORT MIS-WIRE TEST.
  - Contact Resistance: 3 ohm.
  - Insulation Resistance:5 Mega ohm.
  - Hi-pot test:DC 300V/10ms.
  - SOLDERING COPPER FOIL ONTO THE INNER MOLDING.

NOTE	DESCRIPTION
1	DISPLAYPORT 20PIN (MALE) ,WITH PCBA (IC :CH7530A)
2	ABS ASSEMBLY SHELL BODY WITH LATCHES ,BLACK.
3	UL 20276 (32AWG*2C+AL+D)*5C+32AWG*5C+AEB CABLE
4	B792.50P BLCAK PVC
5	HDMI 19PIN (FEMALE) CONNECTOR
6	SCREW NUTS # 4-40* 2PCS

UNLESS OTHERWISE SPECIFIED DIMENSIONS ARE IN MILLIMETERS ANGULAR TOLERANCE: XXXXX		APPROVALS DRAWN PETER. YEH	DATE 2024.10.18	
DIMENSIONS		CHECKED SANDY.CHEN	DATE 2024.10.18	
.X	±0.5	APPROVAL BRYAN.HO		DISPLAYPORT-20PIN(M) TO HDMI (F) , W/SCREW NUTS CABLE, L=300MM
X.	±1	DATE 2024.10.18		
XX.	±10	SIZE C		SCALE : XX : XX
XXX.	±50	DRAWING NO. FT-C292-845		REV. A
ID NO.			SHEET 1 OF 1	